

# BUZZ RACK

## E-HORNET 2

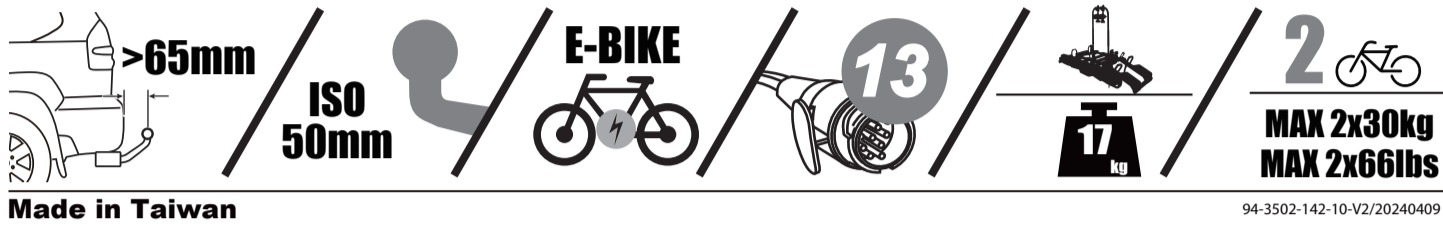

Max		
50 kg		33 kg
60 kg	17 kg	43 kg
70 kg		53 kg
>80 kg		MAX 60 kg



Made in Taiwan

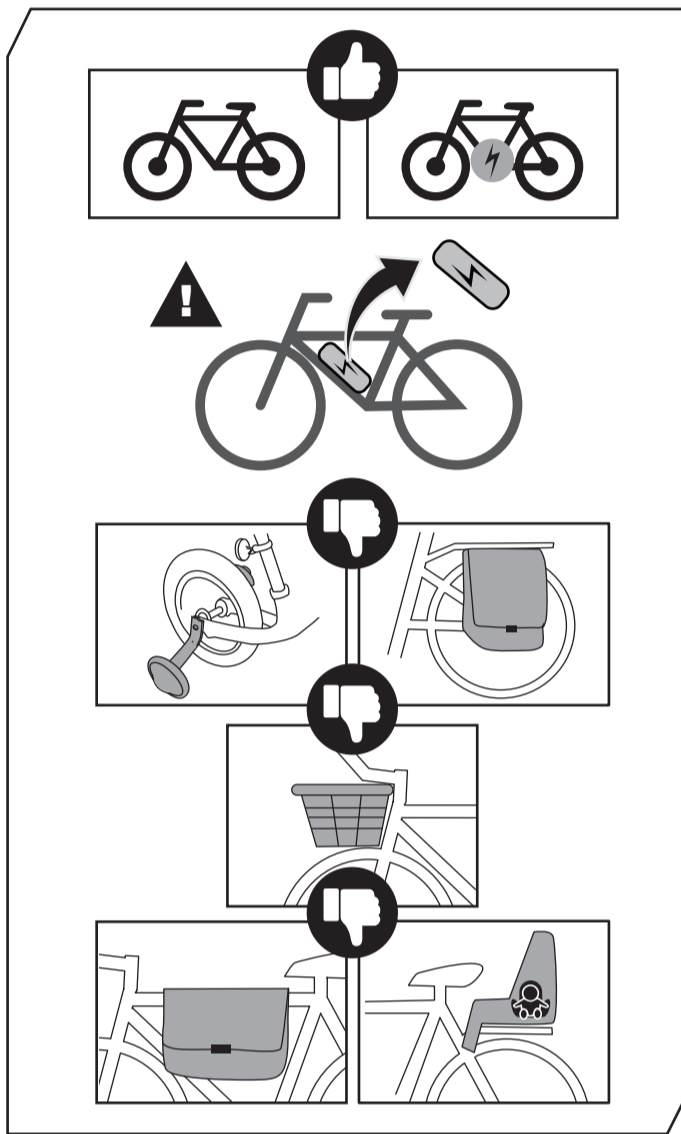

**MAX 60KG**

**E-Bike**

2 x 30kg = MAX 60kg

**Max 4"**

Wheel base

26" Tire diameter	29" Tire diameter
MAX 138cm(54.25")	MAX 140cm(55")

### ACCESSORIES (NOT INCLUDED)

**E-RAMP Alu**  
# 47-0116-002-10

**E-RAMP steel**  
# 47-0116-003-10

**E-RAMP Pro**  
# 47-0116-006-10

**CONNECTOR**  
# 47-0100-042-10

**ANTI-SWAY**  
# 47-0100-045-10

13-pin  
13 to 7-pin

7-pin

**Tool**

x1 x1

x2 x2

•4.0 •5.0

**STEP 2.**

x4 M6x70mm

x2 x8 x4

Ø6.5xØ13 M6x1.0

**STEP 5.**

x2 M6x25mm

x2 M6

x2 Ø6.5xØ13

**STEP 6.**

1

2

3

4

5 5Nm

6 MAX 37.5Kg (82.5Lbs)

4 3/4" (12cm)

ISO 50mm

**STEP 3.**

x2 x2 x2 x2 x2

Ø6.5xØ16

**L&R**

x5.0

**STEP 4.**

M6x70mm x4

x4 x4

x4 x4

**L&R**

**STEP 1.**

x4 x2

**!**

**CHECK!**

7

**maintenance**

**STEP 7.**

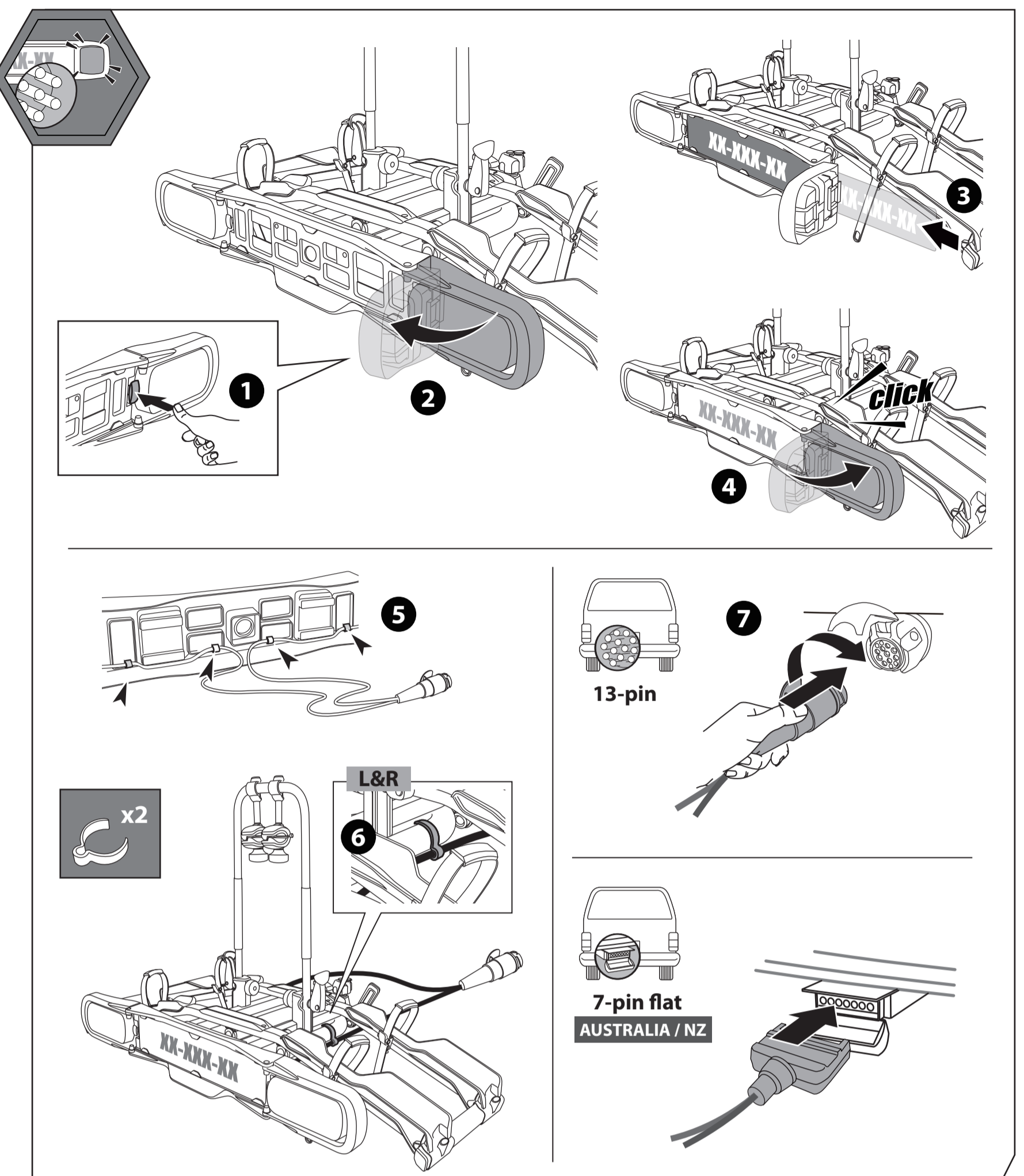

**STEP 8.**

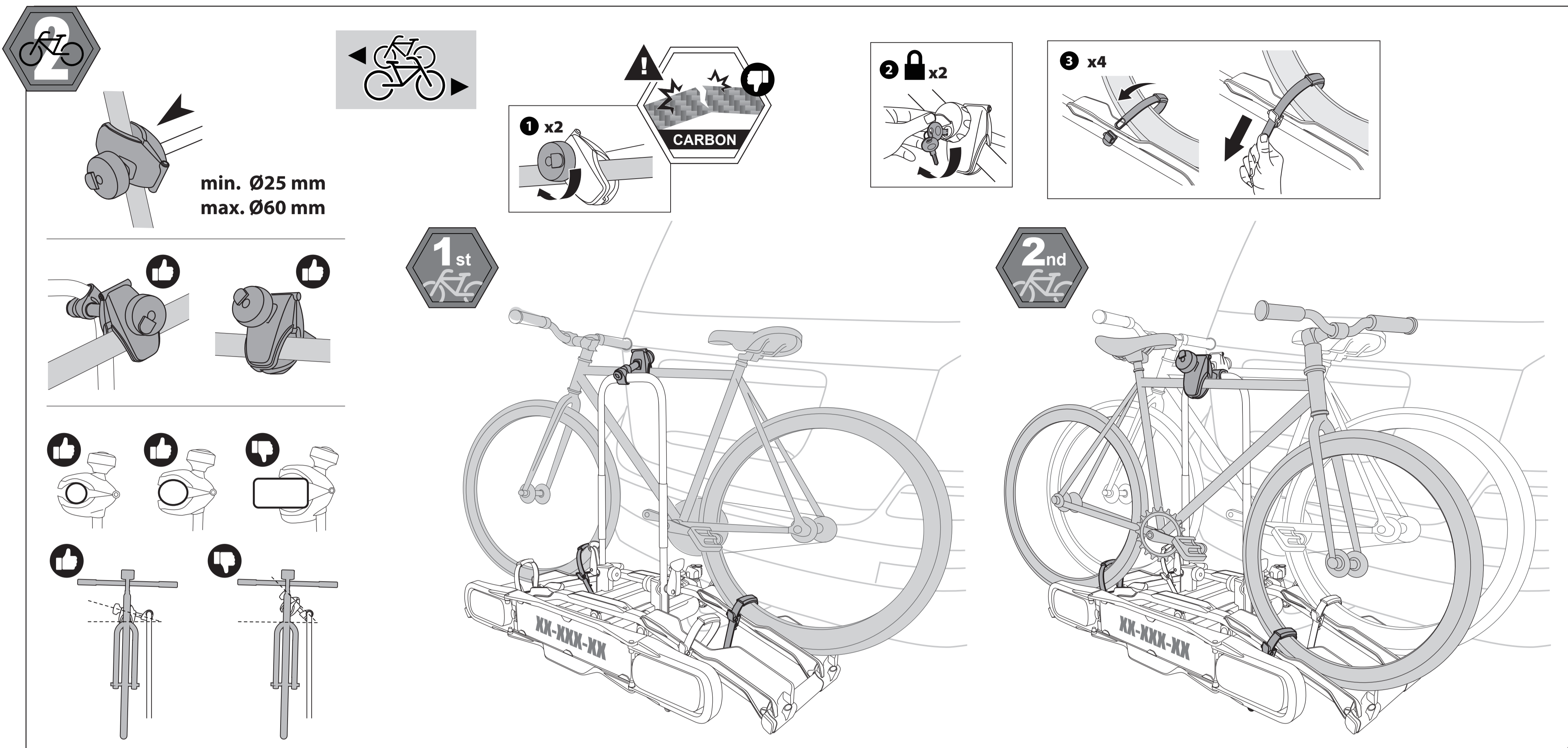

**STEP 9.**

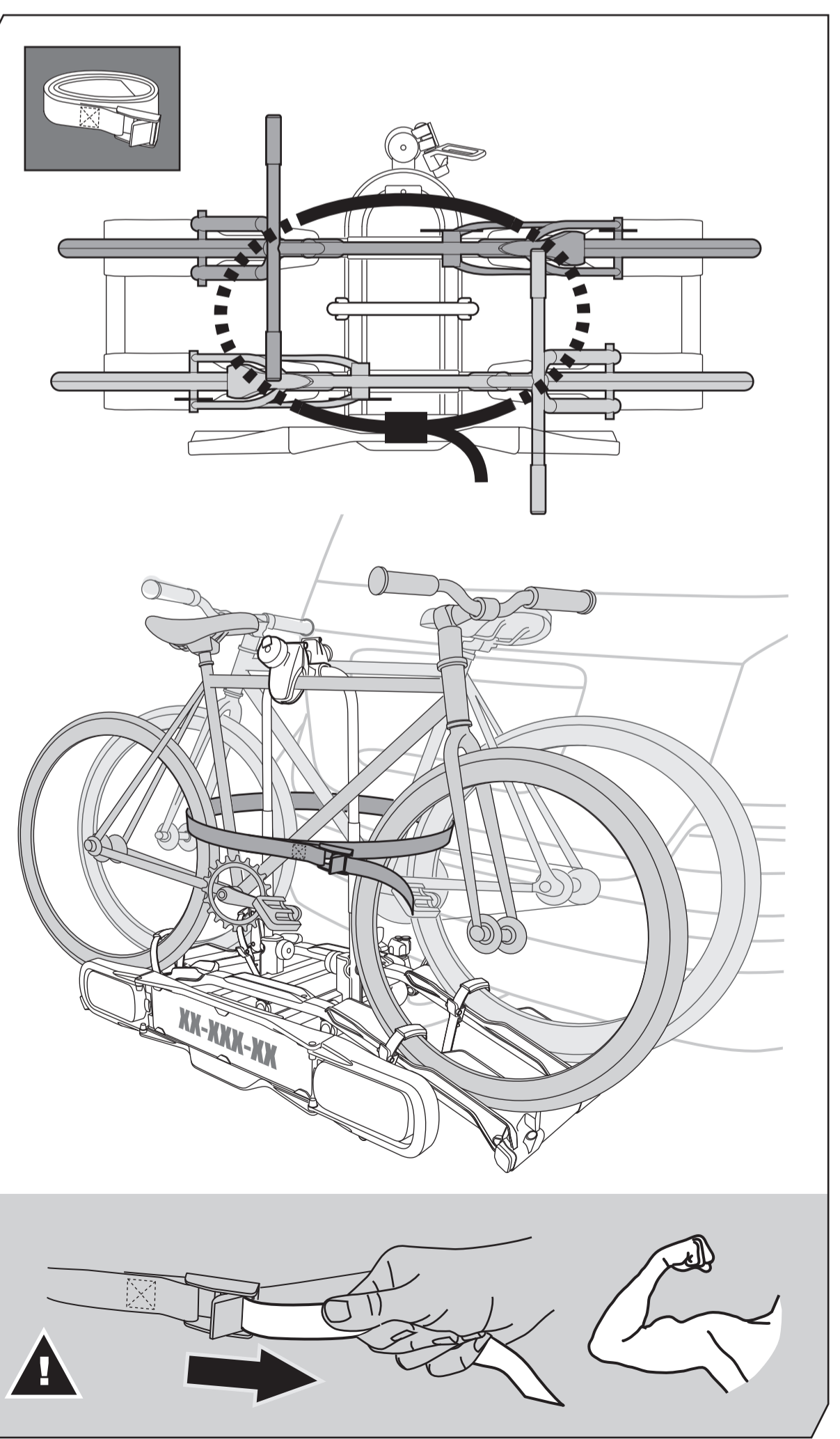

**STEP 10.**

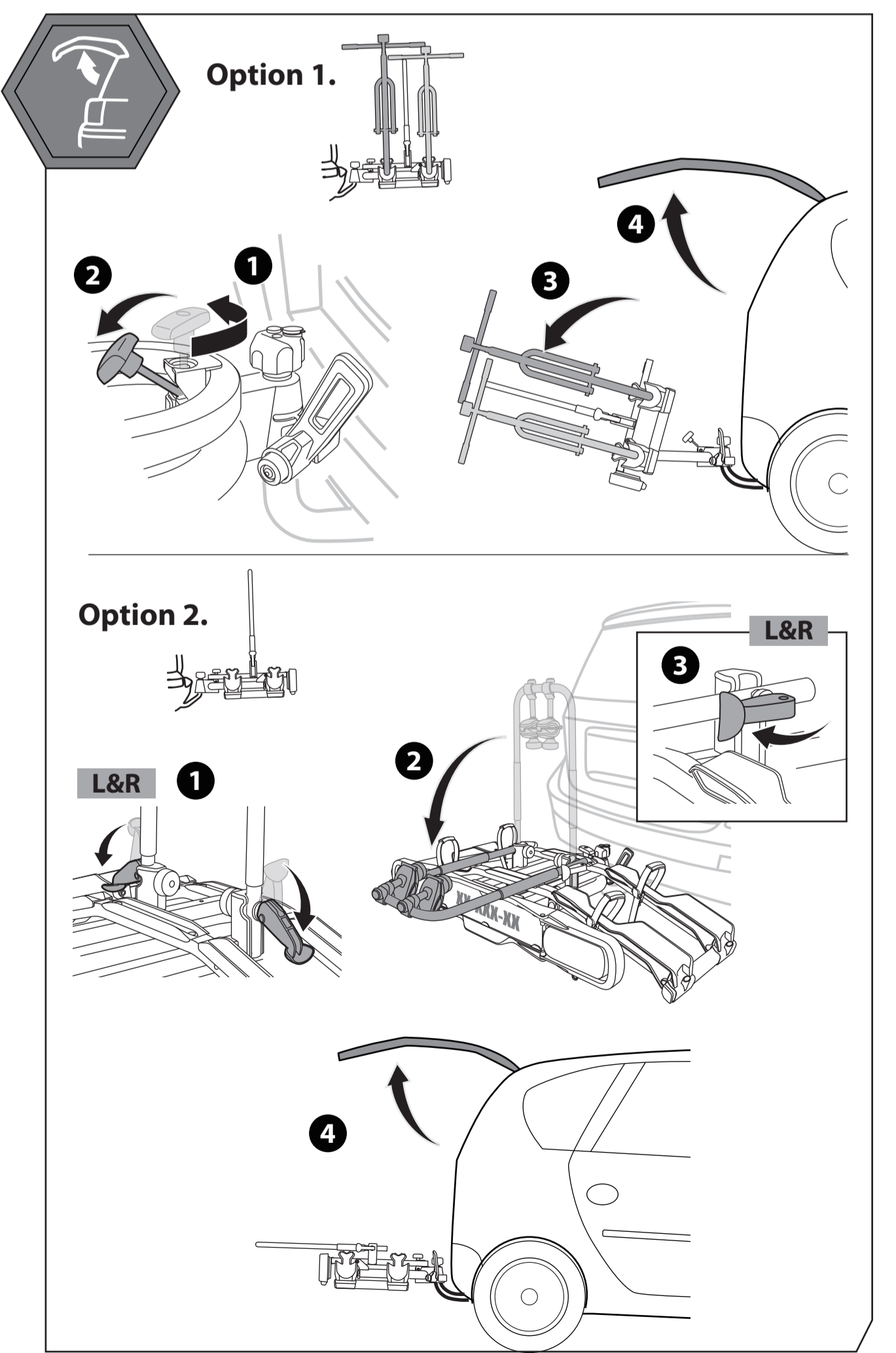

**STEP 11.**

